

Six Sigma in Product Design

Product Design Through Design for Six Sigma (DFSS)

The Start

Olympus Mountain Bikes is a maker of high-quality mountain bikes. It currently offers two lines of mountain bikes: High-end, full suspension carbon frame models, and its volume model platform using steel and aluminium frames. Models based on this platform have been available with front suspension and with a wide range of different quality components to cover the amateur rider as well as the enthusiast.

Like most of its competitors on the market, Olympus Mountain™ assembles its bikes using off-the-shelf components from Shimano® and other major suppliers. The frames are ordered in large-quantity shipments from suppliers in Asia.

Olympus Mountain Bikes has a problem: Technology-driven mountain bike magazines and users are becoming increasingly sceptical on brands assembling bikes using low-cost frames. Market leaders are building their reputation around hand-made frames and an increasing spectrum of technology of in-house technology including custom components and suspension elements.

To maintain market share, breakthrough was needed. Management had two alternatives: enter the low cost, high volume market or attain technological leadership. They decided to take the path to technological leadership.

The Approach

The Mountain Bike has been designed using the IDOV (Identify – Design – Optimise – Verify) approach. In detail the following steps have been done:

- Capturing of VOC and Translating into CTQs (QFD 1)
- Translating CTQ into Functions by QFD 2
- Translating Functions into Designing Mountain Bike Elements (QFD 3)
- Developing Process Indicators and Specifications out of Design Elements (QFD 4)

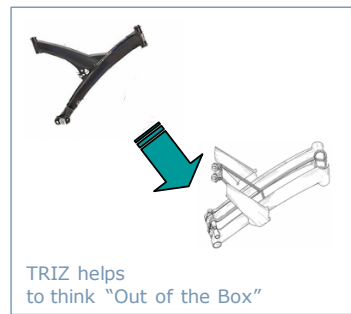

Key tools used during the project work include **Quality Function Deployment (QFD)** and **TRIZ**. The project has been monitored by making use of the **Design Scorecard** in each single define stage.



The Success

The team started with a dream: To design "The bike with the strongest precision-made frame on the market, built to specification at an affordable price".

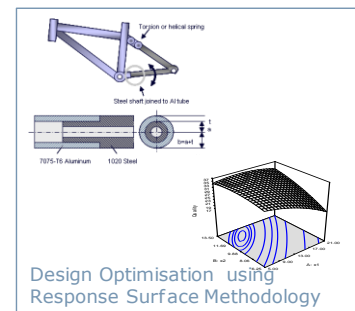

At the end of the project the team was not only able to meet all specifications given by customers and by benchmarking, they were also capable to produce the bike with reasonable costs.

The project cycle time from Chartering until Production of the prototype took not more than 34 weeks.

